

Soil sensor (WET150)

Measures volumetric water content (VWC), electrical conductivity (EC), and temperature of soil. This device, belonging to the PRO sensor series, includes Aranet Sub-GHz ISM band radio which wirelessly transmits sensor measurements to the Aranet PRO base station.



Product numbers

Product number	Radio band	To be used in
TDSPHW02.004	EU868	European Union
TDSPHWU2.004	US920	United States of America, Canada, South America, Australia, New Zealand
TDSPHWU2.004	AS923	BRN, KHM, HKG, IDN, LAO, TWN, THA, VNM, MYS, SGP
TDSPHWJ2.004	JP923	Japan
TDSPHWU2.004	KR923	South Korea

- The product number extension “.004” indicates that this product comes with a 40 cm (1.31 ft) cable, which is the most recent version. Depending on the stock status of previously manufactured units, you might be offered the previous version with a 5 m (16.4 ft) cable (product number without the “.004” extension), which is otherwise identical. For more details, see the *Available accessories* section.
- This product is a bundle consisting of an Aranet transmitter and a WET150 sensor, identified by the product number pattern TDSPHW*2.004 as listed above. The *transmitter alone* has a product number pattern TDSPHM*2.004, which is labeled on the transmitter itself. This product number is also used when identifying soil sensor measurements in the Aranet PRO base station and during data integrations with systems such as Modbus, BACnet, and MQTT.

Sensor performance

General notes

- 95 % of the sensors perform within the specified accuracy limits at the time of purchase, assuming they are in an equilibrium state.
- Device has been carefully optimized to provide accurate readings in soils and substrates. Readings taken in water or air may not meet the full specification.

Volumetric water content

Range	0–100 %
Resolution	0.1 %
Accuracy	±3 %

- The VWC range is dependent on the media the sensor is calibrated to. The accuracy figure is relevant only when the correct VWC profile is selected for the specific soil media being used. See details in section *Configuration available to the user*.
- Given accuracy is typical for mineral soils with electrical conductivity of <8 dS/m. The VWC accuracy is dependent on the media the sensor is calibrated to. A custom calibration can improve the accuracy up to 1 % of VWC reading.

Dielectric permittivity

Range	1–80	
Resolution	0.01	
Accuracy	±3 % (in range 1–40)	±5 % (in range 40–80)

Bulk electrical conductivity

Range	0–12 dS/m
Resolution	0.001 dS/m
Accuracy	±(6 % + 0.1 dS/m)

Temperature

Range	-20–60 °C	-4–140 °F
Resolution	0.1 °C	0.1 °F
Accuracy	±0.7 °C	±1.3 °F

General specifications

Ingress protection rating	IP68	
Operating temperature range	-20–60 °C	-4–140 °F
WET150 dimensions (incl. prongs)	∅40×143 mm	∅1.6×5.6 in
WET150 prong dimensions	∅2.5×51 mm	∅0.1×2.0 in
Aranet transmitter dimensions	∅35×120 mm	∅1.4×4.7 in
Cable length	40 cm	1.31 ft
Total weight (incl. battery, cable)	200 g	7.0 oz
Power supply	1 pc AA battery	
Packaging includes	1 pc AA alkaline battery, Soil sensor stand (TDKWSH01.0004)	

Available accessories

Product number	Description	Packaging
TDKWSH01.004	Soil sensor stand	Included in packaging
TDAWSH01	Soil sensor holder	To be ordered seperately
TDACHM02.050	Transmitter extension cable (5 m / 16.4 ft)	To be ordered seperately

- The Aranet wireless transmitter comes with a 40 cm (1.3 ft) cable, selected for easy installation in the *Soil sensor holder*. However, in cases of dense vegetation and/or suboptimal Aranet base station installation distance, it may be necessary to hang the transmitter above the vegetation for reliable wireless data transmission. In such instances, the *Transmitter extension cable* should be used.
- The *Soil sensor stand* (TDKWSH01.004) enables stable and consistent installation in low-height substrates (7–10 cm / 3–4 in). For taller substrates, however, the *Soil sensor holder* (TDAWSH01) is a more suitable choice, as it allows for a higher installation position. Refer to page 5 for visual representations of these accessories.

Aranet radio parameters

Line of sight range	3 km	1.9 mi
Transmitter power	14 dBm	25 mW
Data transmission interval	1, 2, 5 or 10 min	
Data protection	XXTEA encryption	

- Specifically for JP923 radio band, reduced transmitter power of 13 dBm (20 mW) is used.

Aranet radio bands and channels

Radio band	Channel 1	Channel 2	Channel 3	Channel 4
EU868	868.1 MHz	868.3 MHz	868.5 MHz	—
US920	917.3 and 922.9 MHz	917.5 and 923.1 MHz	917.7 and 923.3 MHz	917.9 and 923.5 MHz
AS923	923.1 MHz	923.3 MHz	—	—
JP923	923.0 MHz	923.4 MHz	—	—
KR923	923.1 MHz	923.3 MHz	—	—

- This table outlines the radio channels utilized by Aranet Sub-GHz radio technology for transmitting sensor data to the base station, complying with the legislation in various regions. To determine availability of this product in your region and the corresponding channels used, refer to the *Product numbers* table at the beginning of this document.

Battery lifetime

Measurement interval	Alkaline battery lifetime	Lithium battery lifetime
1 min	0.8 years	1.0 years
2 min	1.5 years	2.0 years
5 min	3.4 years	4.6 years
10 min	5.8 years	8.2 years

- Battery lifetime data has been obtained by mathematical extrapolation and is provided for descriptive purposes only and is not intended to make or imply any guarantee or warranty.
- Battery lifetime tests and calculations performed assuming device is at 20 °C (68 °F) and using *Fujitsu Premium LR6G07* (alkaline) and *Energizer Ultimate Lithium L91* (lithium) AA batteries as reference.
- The operating temperature range may vary based on the battery type used. Generally, the range for alkaline batteries is between -20–50 °C (-4–122 °F), whereas for lithium batteries, it is -40–60 °C (-40–140 °F).

Pairing process description

As part of the Aranet PRO product series, this device enables wireless sensor reading transmission to the Aranet PRO and PRO Plus base station. Here's how to pair the sensor with the base station:

- **Preparing for pairing:** Place the sensor within 20 m (60 ft) of the base station during pairing. Once paired, it can communicate over a much greater distance (up to 3 km / 1.9 mi line of sight).
- **Power off the sensor:** If the sensor comes with a battery-disconnect pull tab, leave it in place for now. For battery-powered sensors that are already on, open the casing and remove the battery for at least 20 seconds. If the sensor uses a power supply, unplug it. For newer hardware versions, locate the PAIRING button on the sensor PCB which can be used to initiate pairing without the removal of battery.
- **Start the pairing process:** Access the SENSORS menu in the base station Web GUI. Set the measurement interval and select PAIR SENSOR to start the pairing process.
- **Power on the sensor:** Within 2 minutes, pull the battery tab, reinsert the battery, connect the power supply, or press the PAIRING button to initiate pairing.
- **Confirm successful pairing:** A successful pairing is indicated by the sensor appearing in the Web GUI and a specific LED blink sequence on the sensor PCB (one to three short blinks followed by a longer fade-out blink of the LED):

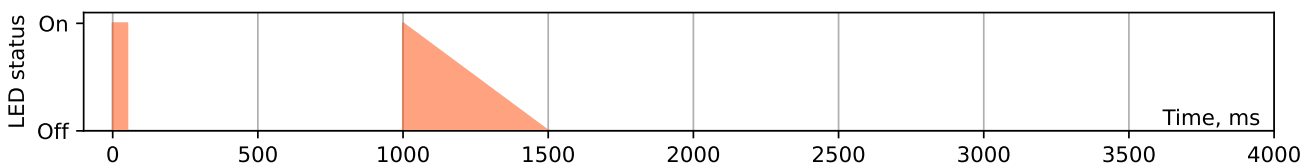

- **Troubleshooting:** If pairing fails, the sensor won't appear in the Web GUI, and the LED blink sequence will consist only of three short blinks. In this case, repeat the process closer to the base station.

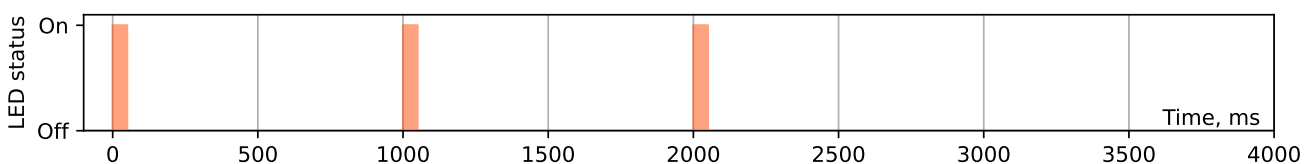

- **Final setup:** After successful pairing, customize parameters like name and tags in the Web GUI. Close the sensor casing and install it in the desired location.

Installation instructions

For accurate and repeatable soil sensor measurements, proper physical installation is crucial. While specific requirements may vary depending on soil type, these general guidelines ensure the quality of sensor readings:

- Choose a location for the sensor installation that reflects the typical plant growth conditions in your facility. Avoid placing the sensor directly next to irrigation fixtures or at extreme ends of slabs, as these areas may differ significantly from overall growth conditions.
- Ensure the sensor is placed in an area with uniform substrate structure around the prongs. Avoid locations with significant air pockets in the media.
- For longer slabs, the most accurate results are obtained by placing the sensor on one of the sides, in the middle of the slab's length.
- Insert the sensor prongs fully into the substrate, ensuring no part of the prongs is exposed. Install the sensor at the same height and location across all substrates to ensure consistent and comparable data.
- Aranet recommends placing the sensor vertically at 32 mm (1.25 in) from the bottom. This corresponds to the 1st position of the *Aranet Soil sensor holder* (product number TDAWSH01). Alternatively, you can install the sensor straight from above into the soil.
- Avoid reinstalling the sensor in the same holes, as this can create air gaps between the substrate and sensor prongs. If reinstalling in the same substrate, choose a different location to form new holes during installation.

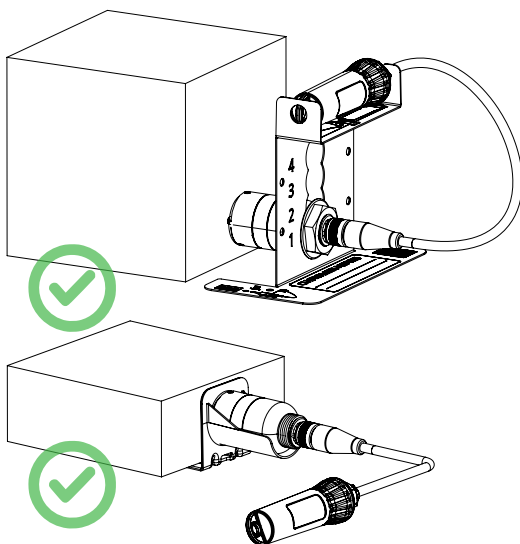

Recommended installation: Placement close to bottom. Repeatable installation using holder accessories. Fully embedded prongs.

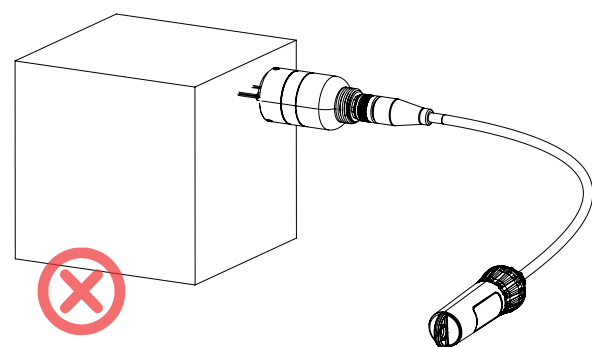

Incorrect installation: Placement close to the slab top. Prongs partially outside the substrate. Unsecured and non-repeatable installation.

Configuration available to the user

Fundamentals of measurement

Measurement	Abbreviation	Designation	Purpose of measurement
Temperature	T	T	General growth condition
Bulk electrical conductivity	ECb	σ_b	Indirect measurement of ECp
Pore electrical conductivity	ECp	σ_p	Water nutrient content
Dielectric permittivity	DP	ε	Indirect measurement of ECp and VWC
Volumetric water content	VWC	θ	Water available to plants

- The *Soil sensor (WET150)* provides several measurements, summarized in the table above. T, ECb, and DP are direct measurements provided by the sensor hardware. However, ECp and VWC are indirect measurements calculated by the Aranet PRO base station using the direct measurements as input data.
- Users can configure the methods for calculating these indirect metrics based on their specific needs and use cases. The sections below describe the configuration options and the reasoning behind adjusting these settings.

Calculating pore electrical conductivity

- ECp measures the conductivity of water pockets between soil particles. While ECb provides insights into nutrient levels in the substrate, ECp reliably represents the nutrient levels of the water available to the plant.
- ECp (σ_p) is calculated from ECb (σ_b) using the Hilhorst formula seen below. In this expression, ε and σ_b are direct measurements of the sensor, but $\varepsilon_{\text{water}}$ and $\varepsilon|_{\sigma_b=0}$ are constants. For more information, refer to: *Hilhorst, M.A. (1998) Dielectric Characterisation of Soil (ISBN 90-5485-810-9)*.

$$\sigma_p = \frac{\varepsilon_{\text{water}}}{\varepsilon - \varepsilon|_{\sigma_b=0}} \sigma_b = \frac{1}{\varepsilon - 2.4} \sigma_b$$

- However, the Hilhorst equation is less accurate when there is insufficient water present. For better performance in low VWC conditions, use the improved Hilhorst model included in the Aranet PRO base station configuration settings for the *Soil sensor (WET150)*. This model provides more stable ECp measurements with smaller data fluctuations when substrate VWC is low.

$$\sigma_p = \frac{\varepsilon_{\text{water}} - \varepsilon|_{\sigma_b=0}}{\varepsilon - \varepsilon|_{\sigma_b=0}} \sigma_b = \frac{80 - 1}{\varepsilon - 1} \sigma_b$$

- You can switch between the *Hilhorst model* and the *Hilhorst model (improved)* in the sensor settings of the Aranet PRO base station under the configuration item *Equation preset*. You can also specify custom value of $\varepsilon|_{\sigma_b=0}$.



Calculating volumetric water content

- The VWC measurement (θ) is derived from the DP measurement (ε) using an empiric functional relationship defined by a 6th order polynomial with coefficients a, \dots, g .

$$\theta = a + b\varepsilon + c\varepsilon^2 + d\varepsilon^3 + e\varepsilon^4 + f\varepsilon^5 + g\varepsilon^6$$

- Different soil substrate types (e.g., rockwool, soil, coir, peat) vary in density, dielectric properties, and water absorption. Consequently, they require different sets of coefficients α, \dots, g to accurately calculate the VWC measurement.
- Sensor configuration menu in the Aranet PRO base station web interface allows you to switch between different soil substrate presets, each with its own set of coefficients. These presets are based on calibration results from the Aranet soil laboratory and other sources.
- After pairing the *Soil sensor (WET150)* with the Aranet PRO base station, configure the soil type preset according to your specific installation. If you are unsure of the substrate type, the *Universal Mineral Soil (Topp)* profile is recommended as the default. For advanced use, you can enter a custom set of coefficients in the configuration settings.

Compliance information

-  Conformité Européenne
 -  Federal Communications Commission (USA)
 -  Innovation, Science and Economic Development Canada
-

Korea certification mark label



R-R-A4A-TDSPHWU2

Company name	SAF Tehnika JSC
Equipment name	Soil sensor (WET150)
Model name	TDSPHWU2 . 004
Manufacturer / Country	SAF Tehnika JSC, Latvia
